

Fabrication of micro end mills by wire EDM and some micro cutting tests

This content has been downloaded from IOPscience. Please scroll down to see the full text.

2009 J. Micromech. Microeng. 19 025004

(<http://iopscience.iop.org/0960-1317/19/2/025004>)

View [the table of contents for this issue](#), or go to the [journal homepage](#) for more

Download details:

IP Address: 131.113.58.246

This content was downloaded on 26/06/2015 at 09:15

Please note that [terms and conditions apply](#).

Fabrication of micro end mills by wire EDM and some micro cutting tests

Jiawang Yan, Kazuyoshi Uchida, Nobuhito Yoshihara
and Tsunemoto Kuriyagawa

Department of Nanomechanics, Graduate School of Engineering, Tohoku University, Aoba 6-6-01,
Aramaki, Aoba-ku, Sendai 980-8579, Japan

E-mail: yanjw@pm.mech.tohoku.ac.jp

Received 21 July 2008, in final form 26 October 2008

Published 14 January 2009

Online at stacks.iop.org/JMM/19/025004

Abstract

Extremely fine end mills with noncircular cross-sectional profiles have been fabricated utilizing wire electro discharge machining. By using suitable electro discharging conditions, the geometrical error of the end mill and the roundness of the cutting edge were both controlled below $1\ \mu\text{m}$. Micro grooving tests were performed on electroless nickel plating using these end mills, and the machining behavior was investigated. Nearly burr-free precision machining was realized. Until a total cutting distance of 1000 mm, no remarkable change was found in the cutting force and chip formation, demonstrating the high anti-wear ability of the tools. It can be presumed that the electro discharge-induced micro asperities on the tool surface play an important role in machining by improving the tribological properties of the tool–workpiece interface.

(Some figures in this article are in colour only in the electronic version)

1. Introduction

The demands for miniaturization of mechanical, optical and optoelectric parts are increasing rapidly. Micro parts enable the manufacturing of compact and functionally integrated products for industrial and household uses. Extremely small parts for micro electro-mechanical systems (MEMS), the size of which is at or below the $10\ \mu\text{m}$ level, are mostly fabricated by photolithography techniques on semiconductor materials. Recently, complex-shape parts of millimeter and submillimeter sizes are increasingly needed, and the substrate materials for these small parts involve metals, ceramics, glass, plastics and so on. To fabricate these kinds of parts, mechanical approaches of material removal and material deformation, such as cutting, grinding, molding and imprinting, become indispensable.

Micro cutting is one of the most important machining technologies for fabricating complex microstructures on metal materials. In micro cutting, end milling is a popular method to fabricate three-dimensional micro structures under multi-axis numerical control [1–6]. In order to perform micro end milling, the fabrication of micro end mills is an important issue. Conventionally, end mills are manufactured by grinding [1]. However, when fabricating end mills having diameters

below the submillimeter level, the grinding forces may cause the bending and breaking of the end mills. Also, subsurface damages caused by grinding will lower the strength of the end mills. Other nonconventional methods, such as focused ion beam (FIB) milling, have also been used for fabricating micro end mills [3], but the material removal rate is very low, leading to a very high production cost.

An alternative method to fabricate micro end mills is electro discharge machining (EDM) [7]. The machining force in EDM is extremely small; thus, the problems of tool bending, breaking, and strength decrease due to subsurface damages can be solved effectively. Recently, EDM fabrication of micro tools has been a new topic of research in the area of micro machining [8–11]. For example, Masaki *et al* used EDM to machine poly-crystal diamond to fabricate spherical micro tools [8].

EDM has also been attempted to fabricate micro end mills. Fleischer *et al* showed the feasibility of fabricating a tungsten carbide end mill of $100\ \mu\text{m}$ diameter by wire EDM [10], and Chern *et al* succeeded in fabricating a $31\ \mu\text{m}$ diameter end mill with simple circular cross-sections [11]. These efforts have demonstrated that micro cutting using EDM-fabricated end mills is a potentially powerful micro machining technique. However, in the previous cutting

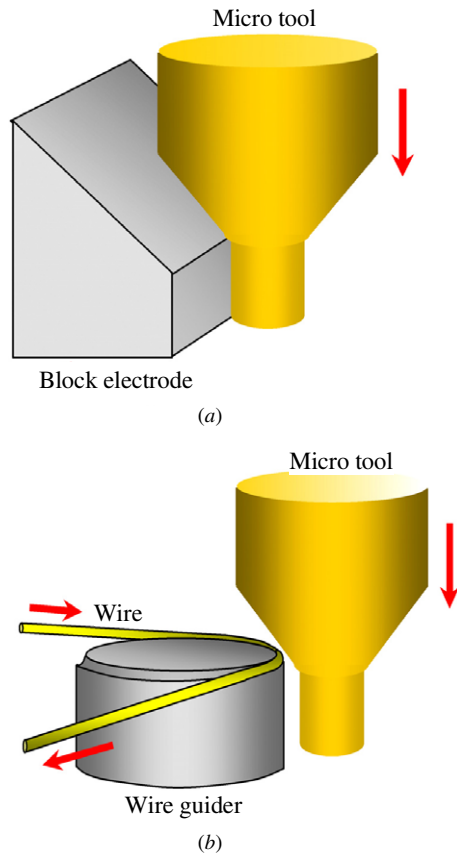

Figure 1. Two EDM methods for fabricating end mills: (a) block electrode EDM and (b) wire EDM.

experiments using the EDM-fabricated tools, burr formation was very significant. Burr formation severely deteriorates the profile accuracy and surface quality of the machined parts, although in micro machining, there are no suitable finishing techniques to remove the burrs. Therefore, burr formation has been a critical problem limiting the industrial applications of the EDM-fabricated micro tools.

In the present work, we attempted to use wire EDM to fabricate micro end mills with noncircular cross-sections. To eliminate burr formation in cutting, we specially paid attention to the design of tool face angles and the sharpening of cutting edges. To accurately examine the machining performances of the fabricated tools, a set of micro cutting tests were performed on electroless nickel plating, a popular material for optical molds, using an ultraprecision machine with the nanometer step resolution. Nearly burr-free micro machining has been realized at a high speed.

2. EDM fabrication of micro tools

2.1. EDM setup

Two EDM methods can be used to fabricate a micro end mill. One is to use a shaped block electrode, as shown in figure 1(a). When feeding the rotating tool against the block electrode, electro discharges occur at the contact area and a reverse shape can then be transcribed to the tool. This method is suitable for fabricating cylindrical and conical tools

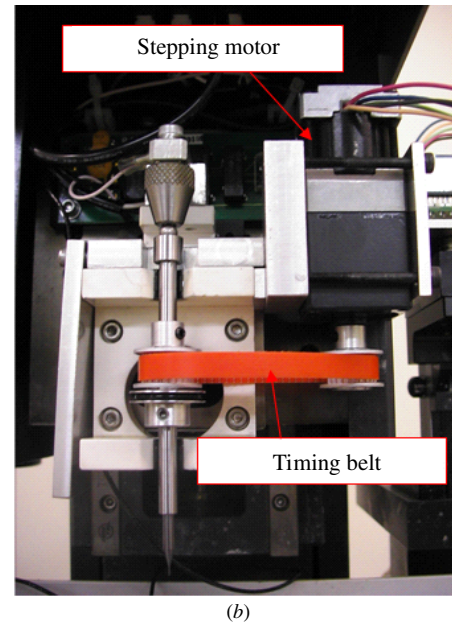
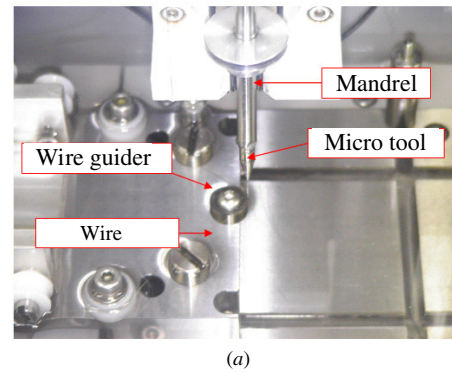

Figure 2. Photographs of the experimental EDM machine: (a) electro discharging section and (b) mandrel driving unit which enables the indexing of the tool.

having circular cross-sections. To make noncircular tools, the fabrication of the block electrode will be difficult. Even if the electrode has been precisely fabricated, during EDM the electrode will be unevenly worn and its shape will change. As a result, the form accuracy of the objective tool is very difficult to guarantee. The other method is to use a fine wire as an electrode which is guided by a rotator, as shown in figure 1(b). This method is termed as wire EDM or wire electro discharge grinding (WEDG) [7]. In contrast to figure 1(a), the contact area between the electrode and the tool in figure 1(b) is extremely small, approaching a single point. By precisely controlling the relative movement between the wire guider and the tool, various complex shapes can be generated onto the tool. In wire EDM, since the wire is fed continuously, the region contacting with the tool is always new. Therefore, a highly precise tool can be fabricated, provided the EDM machine has a high repetitive accuracy and a high step resolution.

A micro wire EDM machine, Panasonic MG-ED82 W, produced by Matsushita Electric Industrial Co., Ltd was used in this study. Figure 2(a) is a photograph of the main section of the machine. The electrode used was a brass wire with a diameter of 100 μm . The wire feeding system

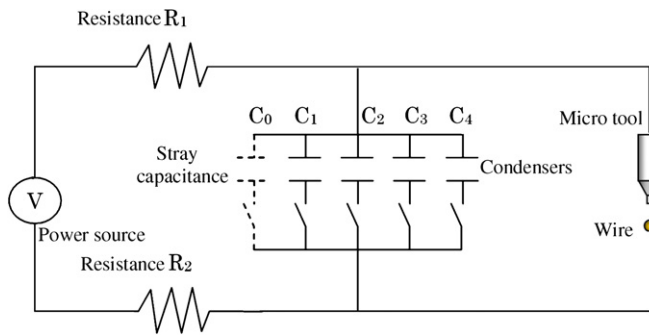

Figure 3. Diagram of the RC circuit used for electro discharging.

is mounted on a table which can move in the horizontal plane under two-axis control. The tool shank (4 mm in diameter) is chucked by a cylindrical mandrel mounted onto a vertically movable table. The machine tables can move at a step resolution of 0.1 μm. The clamping mandrel is supported by V-type ceramic bearings which minimize the decentering errors caused by mounting and detaching. The mandrel can be rotated by either of two driving units. One is a dc motor with a maximum rotation speed of 3000 rpm for high speed applications. The other is a specially equipped driving unit consisting of a stepping motor and a timing belt which enables the indexing of the mandrel at an angular resolution of 0.24°, as shown in figure 2(b). The latter driving unit enables the fabrication of tools with noncircular cross-sections. The conductivity between the mandrel and the electro discharging power source is realized by steel balls.

Two kinds of circuits are usually used for electro discharging: transistor circuit and RC circuit. In this study, the RC circuit is used, as shown in figure 3. The RC circuit can

provide a very small discharging energy by using a condenser of small capacitance. The voltage of the power source can be changed in the range of 0–110 V at a resolution of 1 V. There are two electro discharging modes in figure 3. One is to use condensers C1–C4, whose electrical capacities are 3300, 220, 100 and 10 pF, respectively. The other mode is to use the stray capacitance C0 of the circuit instead of the condensers. As is known from previous studies [12], a sufficiently small discharging energy, namely, a small voltage and/or a small capacitance, is important for micro EDM.

In a conventional high-energy EDM process, discharge-induced evaporation and micro explosions of the surrounding oil are very strong, which help to remove the melted material from the workpiece surface. However, in micro EDM at a low discharging energy level, evaporation and micro explosions of the oil are very weak. As a result, the removed material may be again attached to the workpiece and roughen the surface finish. In this work, we used a pumping system to flow the oil during EDM to prevent material reattaching.

2.2. EDM conditions

Tool geometry, especially the rake angle and relief angle of the peripheral cutting edge of an end mill, is an important factor in controlling chip formation and burr generation. It has been shown by previous researchers that a sharp cutting edge, a non-negative rake angle and a high cutting speed are helpful for eliminating burr formation in micro cutting in metals [13–16]. The circular cross-section end mill in [11] had a negative rake angle and a zero relief angle (clearance angle). This edge geometry is akin to that of abrasive grains in grinding and will be suitable for machining brittle materials,

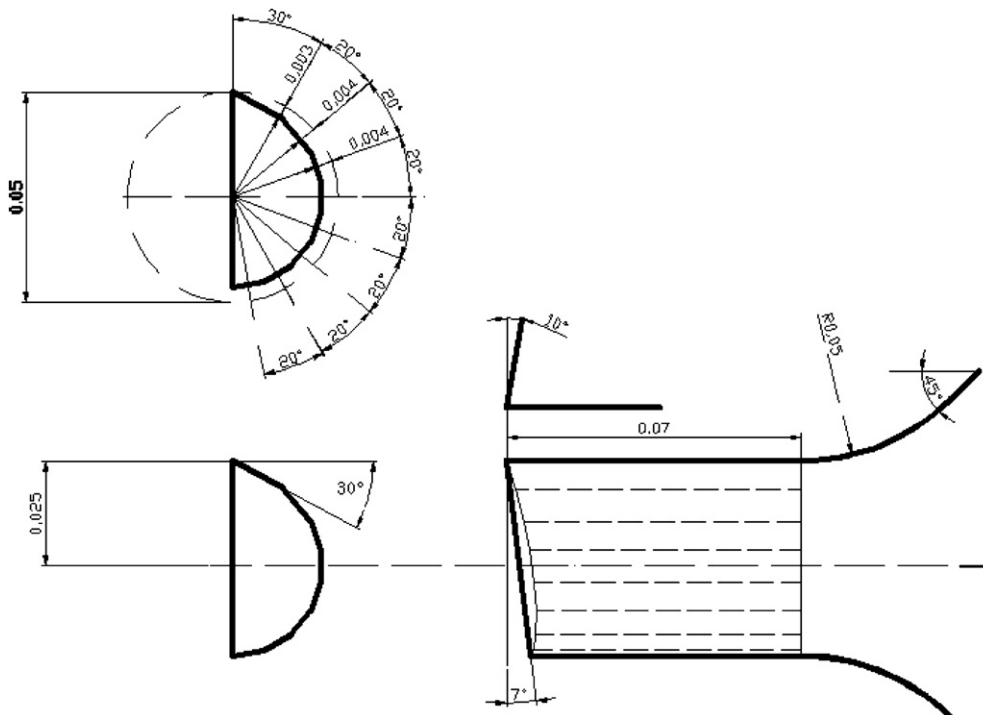

Figure 4. Schematic diagram of the objective tool shape (unit of length: mm).

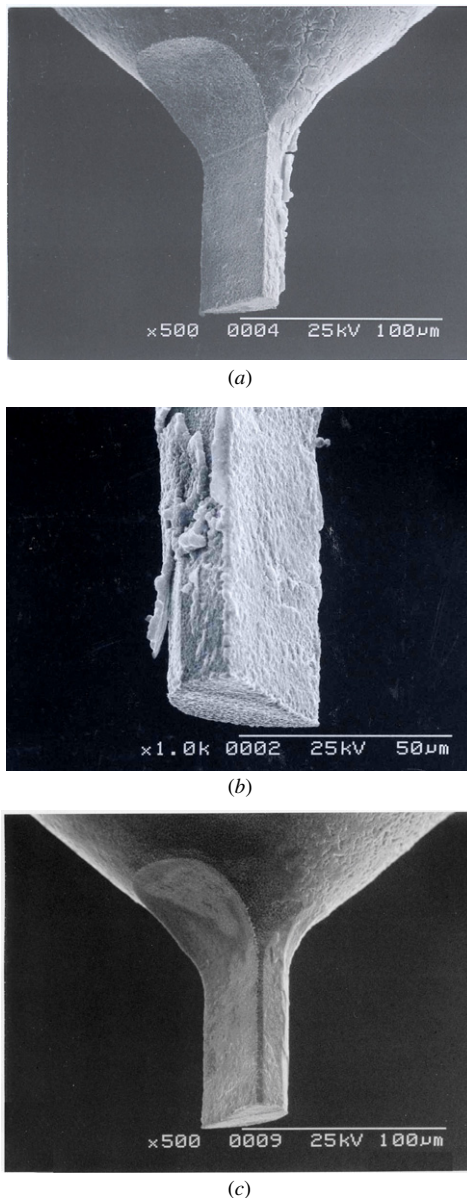

Figure 5. SEM photographs of two fabricated micro end mills: (a) and (b) tool fabricated without using the oil flowing system, showing surface adhesions; (c) tool fabricated using the oil flowing system.

while it is not preferable for metal cutting. In the present work, the rake angle and the relief angle of the peripheral cutting edge were designed to be 0° and 30° , respectively. The 30° relief angle is distinctly larger than those of previous studies, namely 10° [10] and 0° [11]. As shown by Dornfeld *et al* [13], the burr size decreases when increasing the relief angle from about 13° . It is expected that a large relief angle reduces the thrust cutting force and in turn prevent the workpiece material from side flow to form burrs. The objective tool shape of this study is shown in figure 4. The tool has a designed rotational diameter of $50\ \mu\text{m}$. The rake angle, relief angle and the inclination angle of the end cutting edge are 0° , 10° and 7° , respectively.

The material for the end mill is tungsten carbide (WC) MF10, produced by Mitsubishi Material Corporation, which is a popular hard and wear-resistant tool material. The tungsten

carbide particles are smaller than $0.6\ \mu\text{m}$, bound by cobalt (Co) at a volume percentage of 8%. The Rockwell hardness, bending strength and toughness of the material are 93.0 HRA, 4.0 GPa and $5.8\ \text{MPa}\ \text{m}^{-1/2}$, respectively.

First, rough machining was performed under high energy conditions: voltage 80 V and condenser capacitance 10 pF, to generate the end mill's shape from the original cylindrical shape. The material depth left for finish machining was $10\ \mu\text{m}$. The finish machining was performed at a voltage of 70 V using the stray capacitance instead of the condensers. The feed rate of the wire electrode against the tool was set to $2\ \mu\text{m}\ \text{s}^{-1}$. The cutting edges, namely the peripheral edge and the end edge, of the tool were generated by sequentially finishing the peripheral flank face, the rake face and the end flank face. The operation of the EDM machine was automatically controlled by a personal computer.

2.3. Results

The EDM-fabricated micro tools were examined by a scanning electron microscope (SEM). Before SEM observation, the tools were cleaned by acetone in an ultrasonic cleaner and then dried at a temperature of 120°C in air for about 10 min. Figure 5 shows SEM photographs of three fabricated micro end mills. Figures 5(a) and (b) are tools fabricated without turning on the oil flowing system. Without the oil flow, a number of projections are formed on the surfaces of the tools, which are presumably caused by the reattaching of the melted tool material. Material adhesion is especially significant on the peripheral flank face of the tool, because it was generated earlier than other tool faces. Figure 5(c) is a tool fabricated after turning on the oil flowing system while other conditions are the same as those in figure 5(a). In this case, the tool surface is very clean without any adhesion contamination. This result demonstrates that the oil-flowing system is very effective for preventing the melted material from adhering to the workpiece.

The dimension of the end mill shown in figure 5(c) was then measured using a laser microscope. Figure 6 is an example of tool measurement results. From this figure, we can see that the width of the tool rake face is $46.7\ \mu\text{m}$, very close to the theoretical value ($46.3\ \mu\text{m}$) calculated from figure 4. The angle between the end edge and the peripheral edge is 83.2° . Hence, the inclination clearance angle of the end edge is 6.8° , which is also very close to the objective value (7°).

Figure 7 shows SEM photographs of the end mill taken from the direction of the tool end at different magnifications. From figure 7(b), it is seen that the tool surface is not smooth but is densely covered with asperities in the micron level. These micro asperities are the results of local melting and removal of tool material during electro discharges. From the figure, it can also be seen that the tool edge is very sharp, with an estimated edge radius smaller than $1\ \mu\text{m}$. The edge sharpness is an important factor influencing the chip formation behavior although it has not been considered in previous studies. The relief angle of the peripheral edge measured from figure 7(b) is approximately 30° , the same as the objective value.

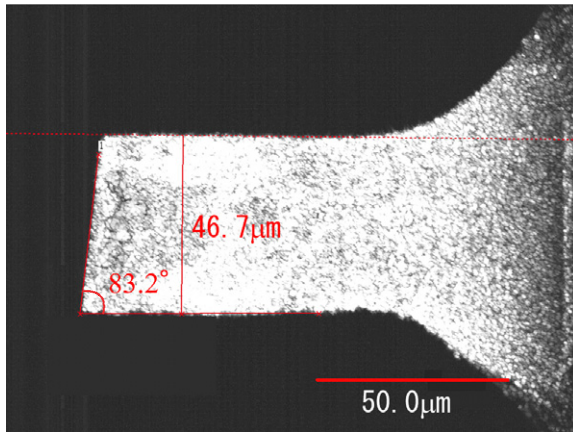
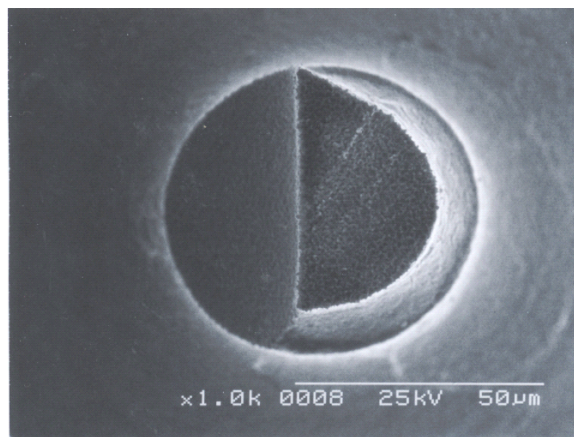
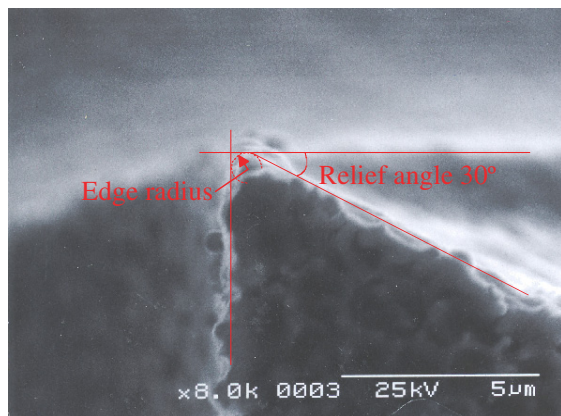

Figure 6. Example of tool measurement using a laser microscope.



(a)



(b)

Figure 7. (a) Low magnification and (b) high magnification SEM photographs of the end mill showing edge radius and relief angle.

3. Micro cutting tests

3.1. Micro cutting apparatus

To examine the performance of the micro end mills fabricated by wire EDM, micro cutting tests were performed. Figure 8 is a schematic presentation of micro end milling. The machine we used is an ultraprecision machine Toyoda AHN-

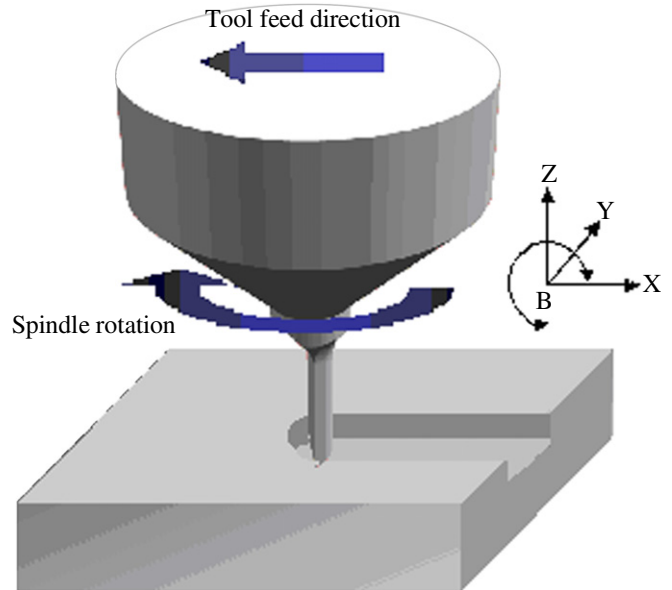

Figure 8. Schematic presentation of micro cutting tests using the EDM-fabricated micro end mills.

05, produced by JTEKT Corporation, Japan. The machine enables its hydrostatic tables to move under four-axis (XYZB) numerical control at a stepping resolution of 1 nm through linear motor driving. The end mill was chucked to a self-balancing air-bearing spindle which has a rotation speed of 10 000 rpm, five times that of the previous studies [10]. Before cutting, the axis of the micro end mill was precisely centered on the rotation center of the spindle using a micrometer. A piezoelectric dynamometer, Kistler 9256 A, was mounted below the workpiece to measure micro cutting forces during the cutting tests.

3.2. Cutting conditions

A steel block with 100 μm thick electroless nickel plating was used as a workpiece. Electroless nickel plating is a hard, ductile and wear-resistant metal which is widely used as mold surfaces for molding curved and/or micro-structured optical and mechanical parts [17–19]. The average Vickers hardness of electroless nickel plating is 600 HV, higher than other workpiece materials in previous studies, such as brass [10], aluminum [11] and copper [2]. In the present study, first, twenty 500 μm long parallel micro grooves were cut on the flat workpiece, leading to an accumulated groove length of 1000 mm which is by far longer than that in previous studies [10]. The tool feeding speed in the X-direction was 20 mm min⁻¹, that is, 2 μm per revolution of the tool. The depth of cut for one tool pass was set to 4 μm. As a lubricant and coolant, the Bluebe # LB10 cutting oil was used in the form of a mist jet.

3.3. Results and discussion

Figure 9 is an SEM photograph of the last one (20th) of the 20 grooves. The groove surface is smooth and flat and the average size of the burrs is approximately ~1 μm, although

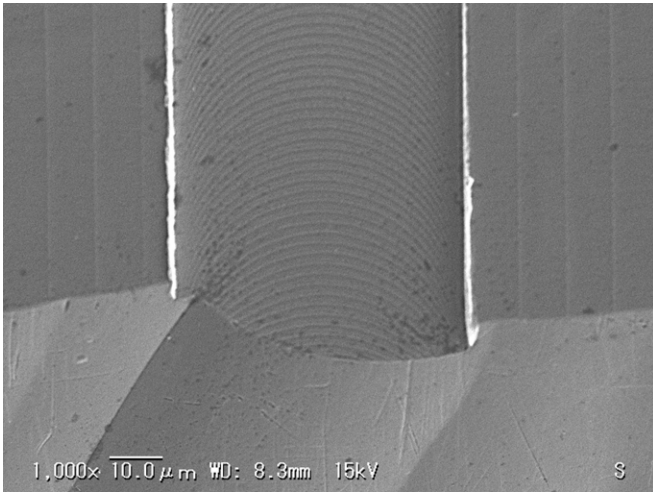

Figure 9. SEM photograph of a micro groove machined after a total cutting distance of 950 mm.

periodical tool feed marks with a pitch of 2 μm (same as the tool feed) can be clearly seen at the groove bottom. Figure 10

shows three plots of cross-sectional profiles of the grooves at different cutting distances. It can be seen that the groove width (50 μm) and depth (4 μm) are almost the same, the change of which with the cutting distance is smaller than 1 μm. This result indicates that the wear of both the peripheral edge and the end edge of the end mill is very small.

Figure 11 shows SEM photographs of the end mill after the cutting tests. Although a small amount of the workpiece material is attached to the tool rake face, the tool tip and the cutting edges are still sharp. The micro asperities on the tool surface can still be clearly identified, demonstrating that the tool wear was insignificant. Figure 12 is a plot of the thrust force against the cutting distance. There is a slight increase in the force as the cutting distance extends, but the change is not remarkable. Figure 13 shows SEM photographs of cutting chips collected at different distances. All the chips are of a continuous flow type and curled uniformly, the appearance of which shows no obvious change with the cutting distance. These results again indicate that the micro cutting process using the EDM-fabricated tool is very stable.

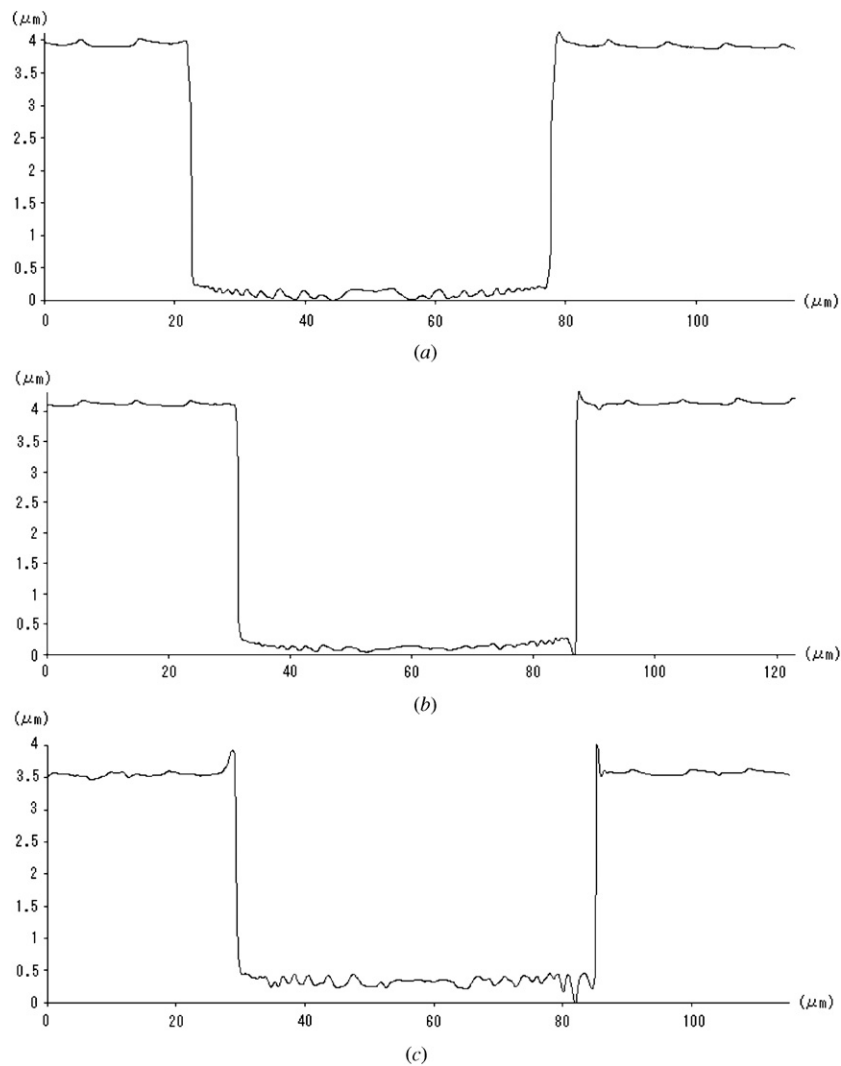
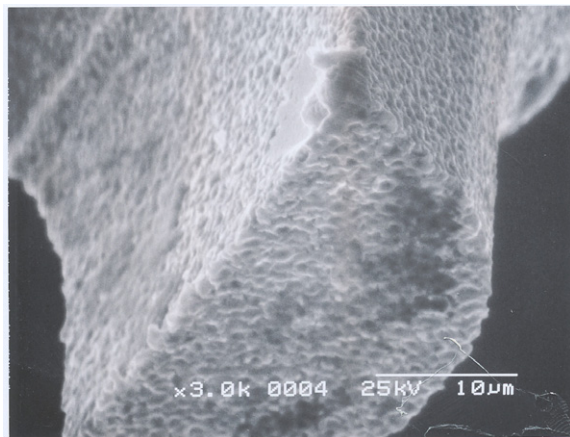
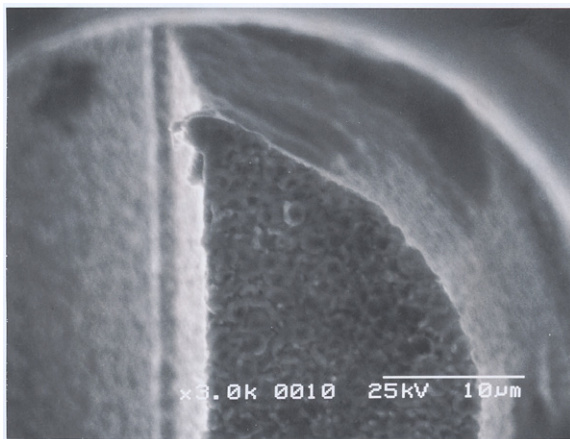

Figure 10. Plots of cross-sectional profiles of grooves cut at different cutting distances: (a) 50 mm, (b) 450 mm and (c) 950 mm.



(a)



(b)

Figure 11. SEM photographs of the end mill after the cutting tests, showing no obvious wear.



(a)

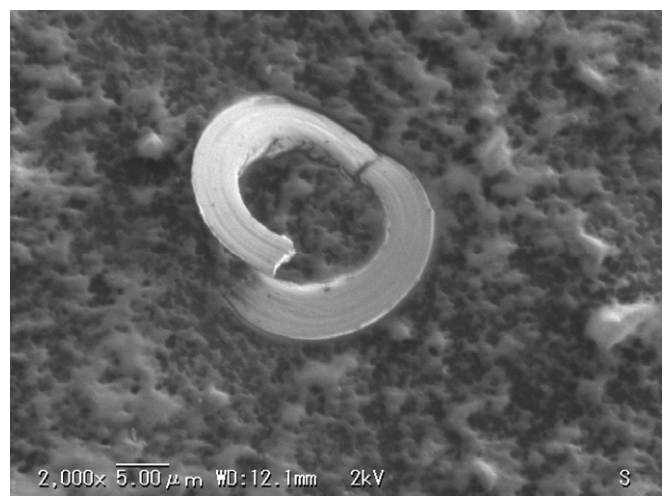

(b)



(c)

Figure 13. SEM photographs of cutting chips collected at different cutting distances: (a) 50 mm, (b) 450 mm and (c) 950 mm.

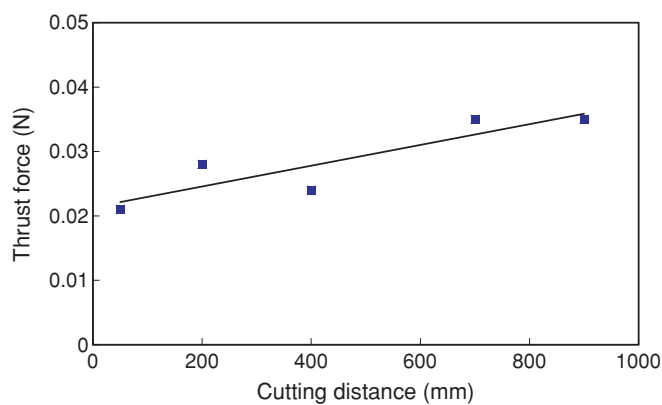

Figure 12. Plot of the thrust force against the cutting distance.

As mentioned above, the EDM-fabricated tool surface is far from smooth, but roughened by micron-level asperities. Conventionally, this kind of rough tool must be polished before using. However, the results from the present study indicate that even by directly using an EDM-fabricated tool, the cutting performance is acceptable. This effect might be indebted to the advantage of surface micro asperities. As

schematically shown in figure 14, the micro asperities help to absorb and store micro oil droplets from the lubricant mist jet during the non-cutting half-revolution of the tool. The stored oil droplets then effectively lubricate the tool–chip contact

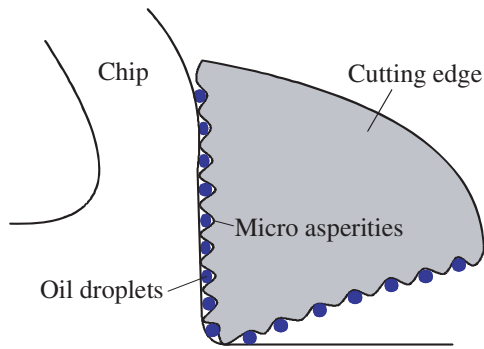

Figure 14. Schematic model of material removal during cutting. The micro surface asperities of the tool improve the tribological properties of the tool–workpiece interface.

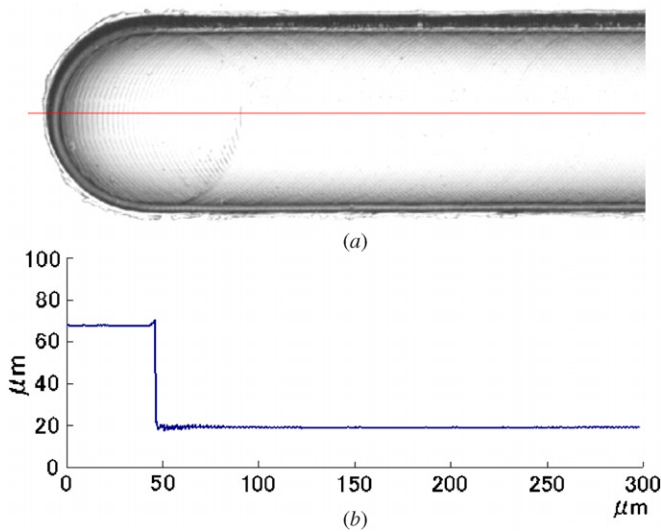

Figure 15. (a) Micrograph and (b) longitudinal cross-sectional profile of a 500 μm long, 50 μm deep groove.

region and, in turn, prevent the tool from wearing. The micro asperities also decrease the effective contact area between the tool and the chip, leading to a low friction coefficient. Therefore, we presume that the electro discharge-induced micro asperities on the tool surface may play an important role in machining by improving the tribological properties of the tool–workpiece interface. This effect might be equivalent to the micro texturing of tool surfaces using other surface processing technologies [20].

Micro end milling can also be used to cut deep grooves. Figure 15 shows a micrograph and a longitudinal cross sectional profile of a 500 μm long, 50 μm deep groove cut by 25 tool passes (depth of cut per tool pass: 2 μm). The machined surface is smooth and flat, without burr formation and chip adhesion. The cross-sectional profiles are very straight with sharp corners. Figure 16 is a micrograph of another micro-machined sample by the micro end mill. The total machining time for this sample was approximately 3 min. Since the depth and orientation of the micro grooves can be freely controlled by a computer program, micro end milling using EDM-fabricated tools provides an efficient and

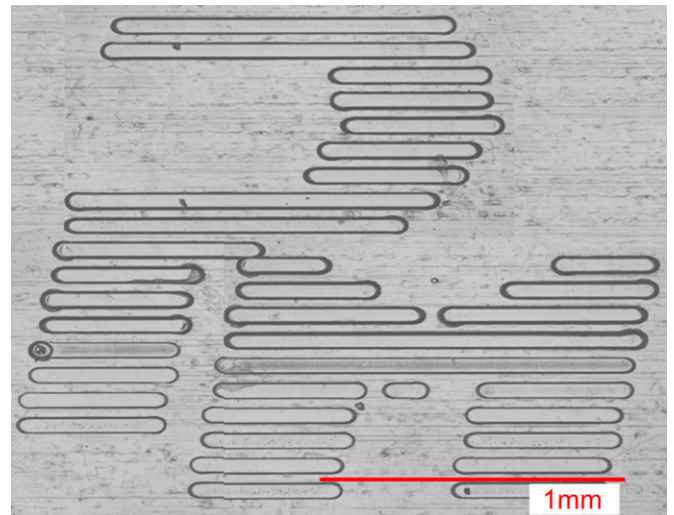

Figure 16. Micrograph of a sample with micro patterns machined by the EDM-fabricated micro end mill.

flexible manufacturing technique for micro grooves and other microstructures on flat or curved metal surfaces.

4. Conclusions

Micro end mills have been fabricated using wire EDM, and their micro cutting characteristics have been investigated. The main conclusions obtained from this study can be summarized as follows.

- (1) End mills of 50 μm diameter with noncircular cross-sectional profiles can be precisely fabricated utilizing wire EDM. By using a suitable discharging energy, both the geometrical error and the edge roundness of the fabricated tool can be controlled below 1 μm and the angle error below 1°.
- (2) The EDM-fabricated micro tools can be used for high-speed end milling micro rectangular grooves of various depths on electroless plated metal material without burr formation. The tool wear is insignificant and the cutting performance is stable.
- (3) Suitable tool geometry and cutting edge sharpness are essential factors for eliminating burr formation in micro cutting. The electro discharge-induced micro asperities on the tool surface play an important role in machining by improving the tribological properties and lubricating conditions of the tool–workpiece interface.

References

- [1] Schaller T, Bohn L, Mayer J and Schubert K 1999 Microstructure grooves with a width of less than 50 μm cut with ground hard metal micro end mills *Precis. Eng.* **23** 229–35
- [2] Rahman M, Senthil Kumar A and Prakash J R S 2001 Micro milling of pure copper *J. Mater. Process. Technol.* **116** 39–43
- [3] Adams D P, Vasile M J, Benavides G and Campbell A N 2001 Micromilling of metal alloys with focused ion beam-fabricated tools *Precis. Eng.* **25** 107–13

- [4] Uhlmann E, Piltz S and Schauer K 2005 Micro milling of sintered tungsten-copper composite materials *J. Mater. Process. Technol.* **167** 402–7
- [5] Rusnaldy T J Ko and Kim H S 2007 Micro-end-milling of single-crystal silicon *Int. J. Mach. Tools Manuf.* **47** 2111–9
- [6] Li H, Lai X, Li C, Feng J and Ni J 2008 Modelling and experimental analysis of the effects of tool wear, minimum chip thickness and micro tool geometry on the surface roughness in micro-end-milling *J. Micromech. Microeng.* **18** 025006
- [7] Masuzawa T, Fujino M and Kobayashi K 1985 Wire electro-discharge grinding for micro-machining *Ann. CIRP* **34** 431–4
- [8] Masaki T, Kuriyagawa T, Yan J and Yoshihara N 2007 Study on shaping spherical poly crystalline diamond tool by micro-electro-discharge machining and micro-grinding with the tool *Int. J. Surf. Sci. Eng.* **1** 344–59
- [9] Hung J C, Lien S C, Lin J K, Yuan Huang F and Yan B H 2008 Fabrication of a micro-spherical tool in EDM combined with Ni-diamond co-deposition *J. Micromech. Microeng.* **18** 045010
- [10] Fleischer J, Masuzawa T, Schmidt J and Knoll M 2004 New applications for micro-EDM *J. Mater. Process. Technol.* **149** 246–9
- [11] Chern G L, Engin Wu Y J, Cheng J C and Yao J C 2007 Study on burr formation in micro-machining using micro-tools fabricated by micro-EDM *Precis. Eng.* **31** 122–9
- [12] Egashira K, Matsugasako A, Tsuchiya H and Miyazaki M 2006 Electrical discharge machining with ultralow discharge energy *Precis. Eng.* **30** 414–20
- [13] Dornfeld D A, Kim J S, Dechow H, Hewson J and Chen L J 1999 Drilling burr formation in titanium alloy, Ti-6Al-4 V *CIRP Ann.—Manuf. Technol.* **48** 73–6
- [14] Lee K and Dornfeld D A 2005 Micro-burr formation and minimization through process control *Precis. Eng.* **29** 246–52
- [15] Filiz S, Conley C M, Wasserman M B and Ozdoganlar O B 2007 An experimental investigation of micro-machinability of copper 101 using tungsten carbide micro-endmills *Int. J. Mach. Tools Manuf.* **47** 1088–100
- [16] Chern G L 2006 Experimental observation and analysis of burr formation mechanisms in face milling of aluminum alloys *Int. J. Mach Tools Manuf.* **46** 1517–25
- [17] Yan J, Sasaki T, Tamaki J, Kubo A and Sugino T 2004 Chip formation behavior in ultra-precision cutting of electroless nickel plated mold substrates *Key Eng. Mater.* **3** 257–8
- [18] Masuda J, Yan J and Kuriyagawa T 2007 Application of the NiP-plated steel molds to glass lens molding *Proceedings of 10th International Symposium on Advances in Abrasive Technology (Dearborn, MI, 25–28 September)* pp 123–30
- [19] Yan J, Oowada T, Zhou T and Kuriyagawa T 2008 Precision machining of microstructures on electroless-plated InP surface for molding glass components *Proc. 8th Asia-Pacific Conf. on Materials Processing (Guilin-Guangzhou, China, 15–20 June)* pp 1085–90
- [20] Enomoto T, Watanabe T, Aoki Y and Ohtake N 2007 Development of a cutting tool with micro structured surface *Trans. Japan Soc. Mech. Eng. C* **73** 288–93